

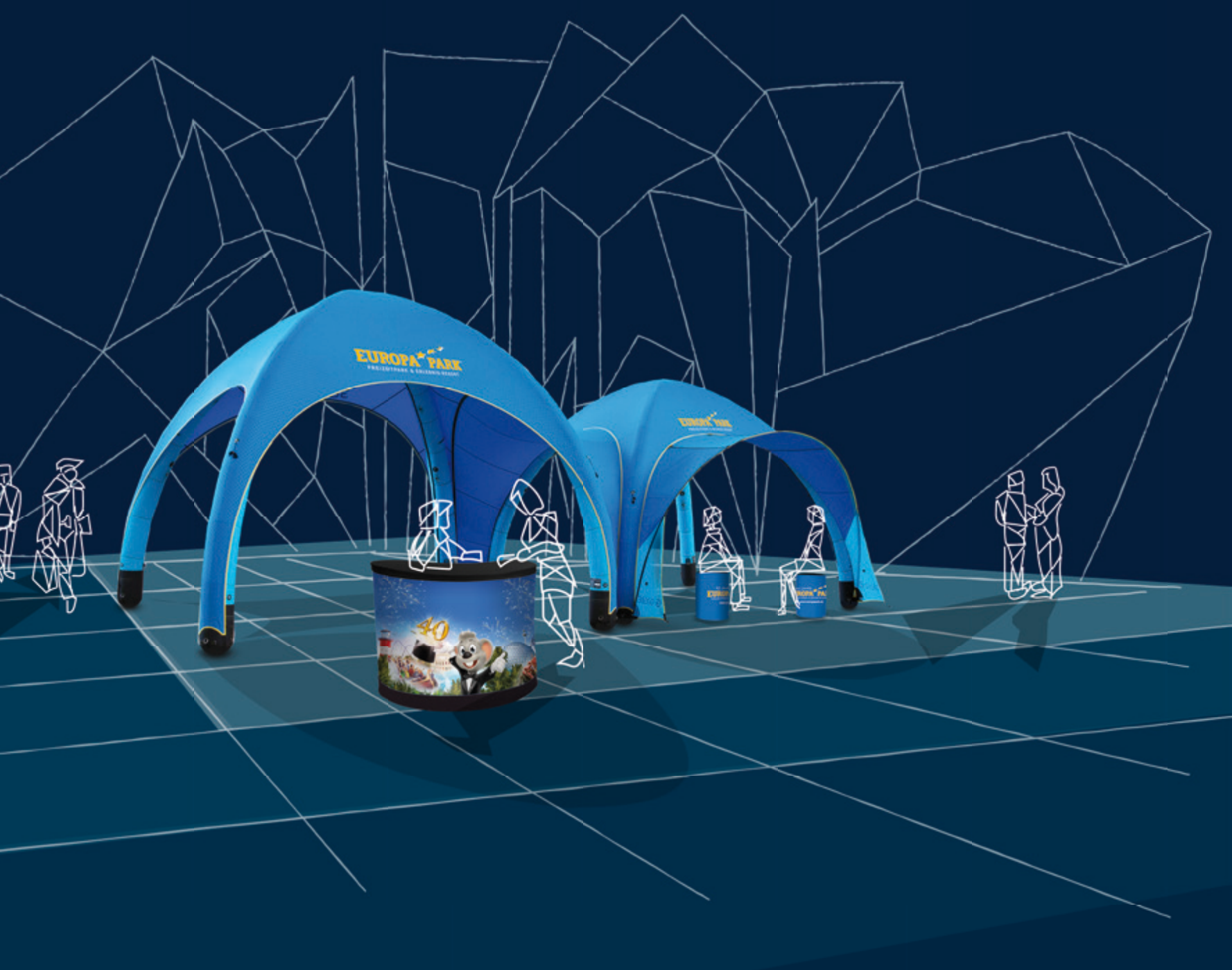

**GYBE**



**Inflatable Event Tents & Accessories**



## IT'S ALL INFLATABLE!

GYBE® provides a wide range of inflatable products that create a promotionally space for events, roadshows, incentives and product presentations. The extraordinary products of GYBE® are perfectly combinable and create a functional and visual unit.

In sum, the perfect set to display and highlight your creative and individual design. The Event Tent creates the room, the Star Lounge the atmosphere, the Counter is the ideal presentation display and the Sitting Tube invites to take a seat.

Unlike other inflatable tents, our tent does not require continual inflation in order to remain upright. The unique GYBE® One-Pump-system easily allows to inflate the tent through a central inflation valve quickly.

## THE GYBE® EVENT TENT

The inflatable GYBE® Event tent creates the optimal room, the perfect atmosphere and the ideal space for your advertising message.

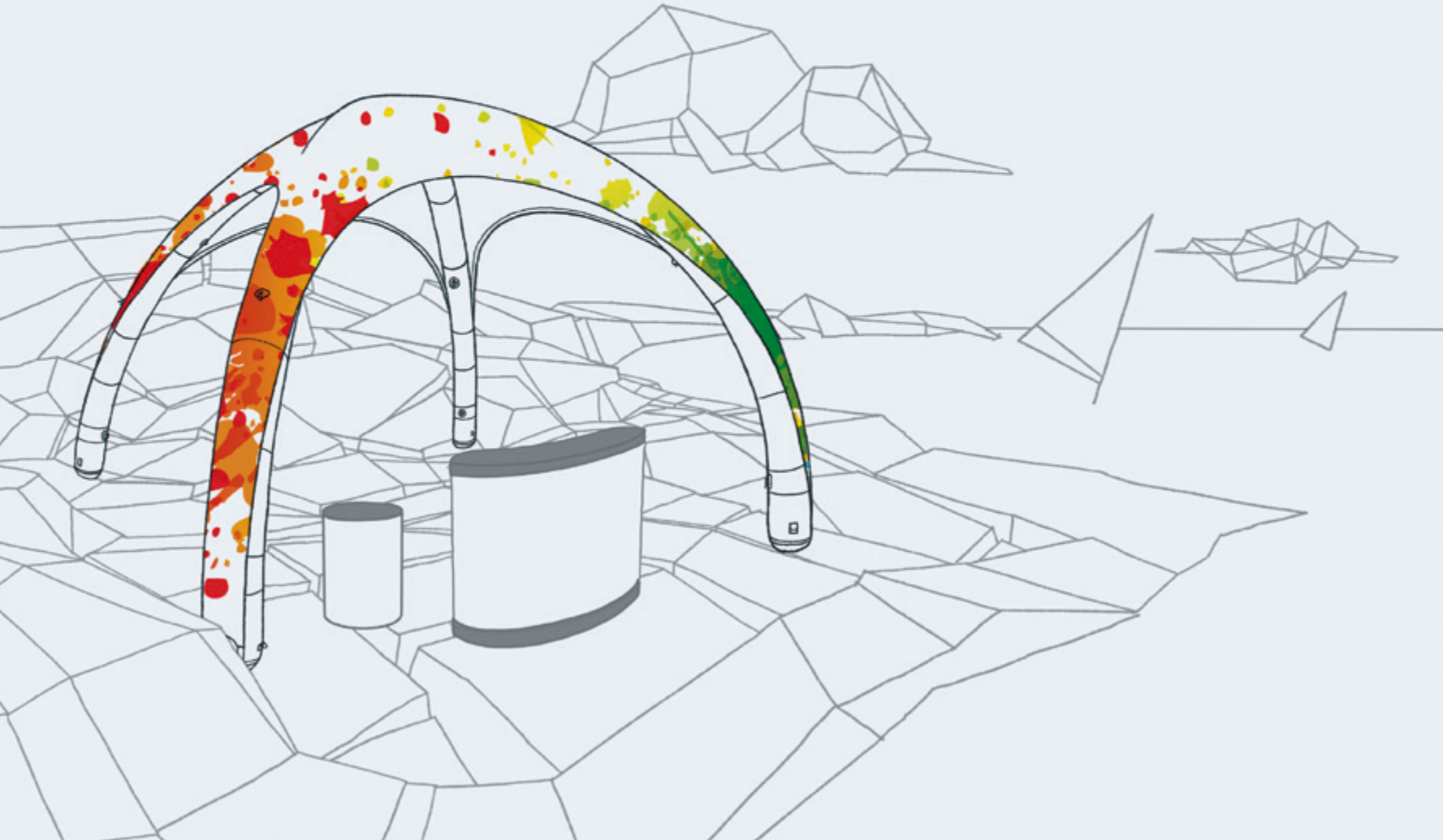

## UNPACK - INFLATE - READY!

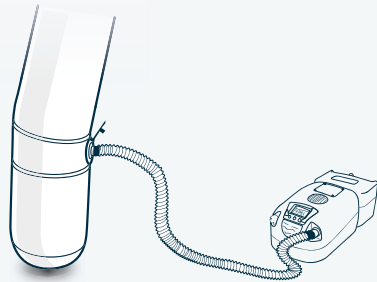

Due to the lack of heavy bars, the tent's transportation is easy and it can be built up by one person in less than **5 minutes**.

The standardized One-Pump-System allows for inflation of the tent via pump through a central inflation valve. A central valve and an integrated distribution system enables the air to flow evenly to the three chambers.

Unlike other inflatable tents, our tent does not require continual inflation in order to remain upright.

## TECHNICAL DETAILS

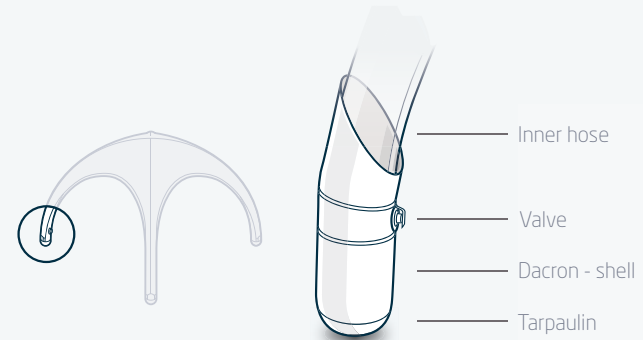

The inflatable supporting structure consists of a high-strength Dacron-shell. We use an elastic PU-foil for the hermetical interior hose.

This construction has been tested under heaviest conditions in the Kite-sports thousands of times.

## MODULAR AND EXTENDABLE

GYBE® offers an unsurpassed selection of extensions and freely selectable sidepanels for its Event Tents.

By using the extension, you can create a wide open space or individual theme worlds. The removable roof and sidpanels can be perfectly adjusted for each event.

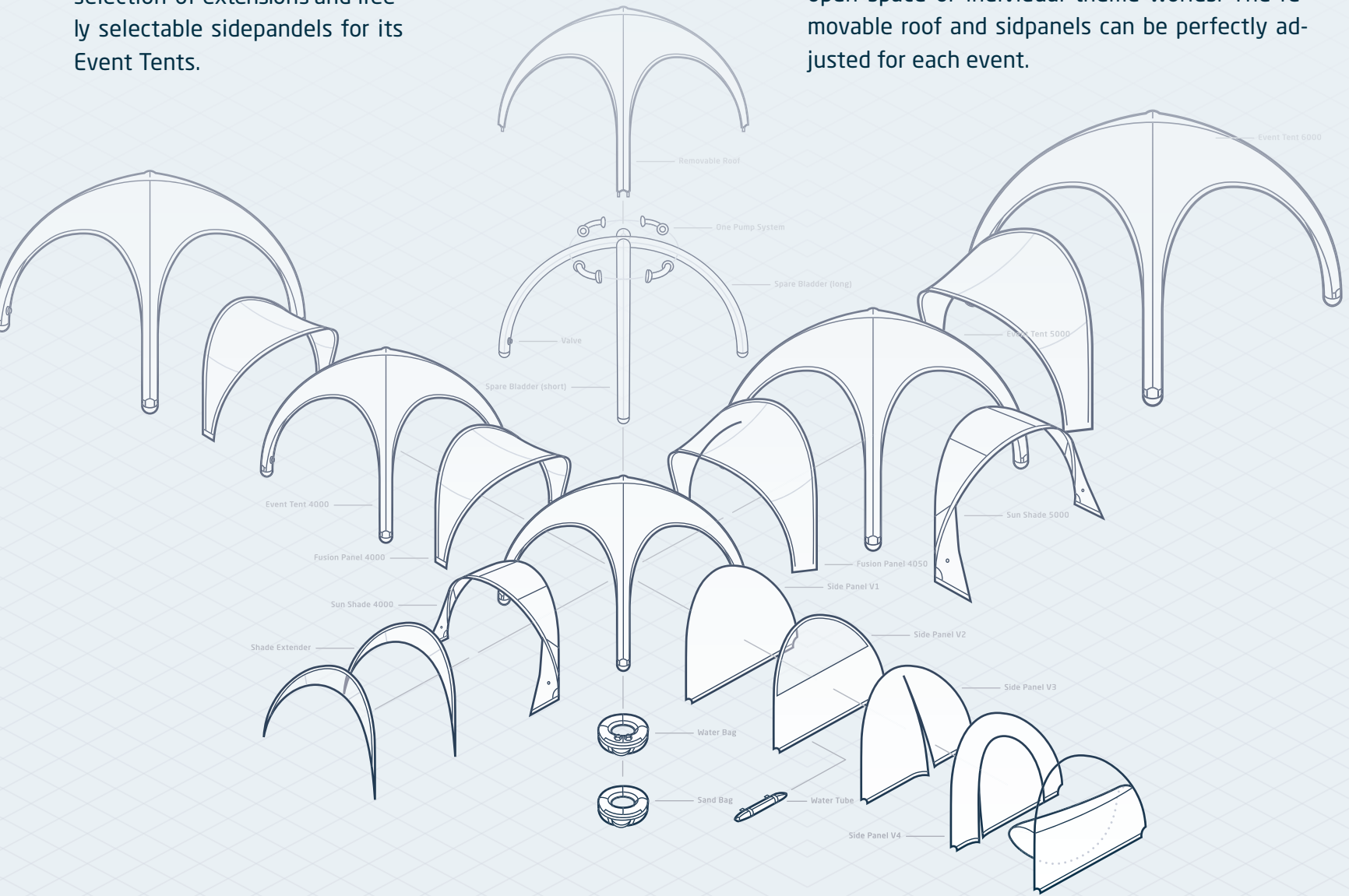

## FEATURES

All extensions can be customized by different printing processes and will perfectly match to the high demands.

## ONE PUMP SYSTEM

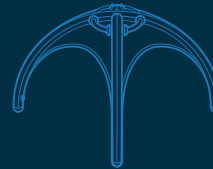

The standardized One-Pump-System allows for inflation of the tent via pump through a central inflation valve. A central valve and an integrated distribution system enables the air to flow evenly to the three chambers. The tent is set up in under 5 minutes.

## SIDE PANELS

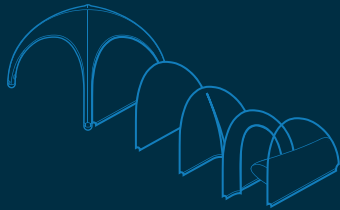

For the EVENT TENT, GYBE offers six different types of sidepanels, which can be exchanged and vary to your desires. All side panels can be selected with the additional option "double zipper" (DZ) and/or "rotating zipper" (RZ).

## FUSION PANEL

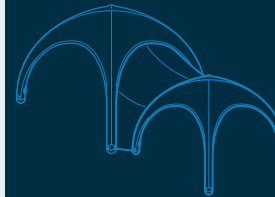

Tents of various sizes can be connected to cover a larger area and to create an impressive scenery of dome tents.

## REMOVABLE ROOF

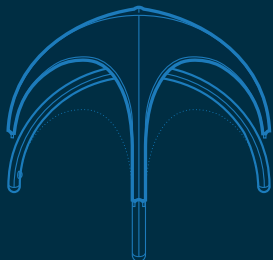

The Removable Roof offers highest flexibility: With only a minimum of installation work it is possible to take off the canopy and exchange it with one of a different color.

## SUN SHADE & SHADE EXTENDER



By using the Sun Shade or the Shade Extender, you cannot only extend the shadow-casting side but also enlarge the printable advertising space.



## DIMENSIONS

	4000	5000	6000
Height	3.0 m	4.2 m	4.9 m
Width	4.0 m	5.0 m	6.0 m
Length	4.0 m	5.0 m	6.0 m
Base area	16.0 m <sup>2</sup>	25.0 m <sup>2</sup>	36.0 m <sup>2</sup>
Height of doorway	2.2 m	2.45 m	3.27 m



Weight	15 KG	19 KG	24 KG
--------	-------	-------	-------



## SET UP TIME

	4000	5000	6000
Double Action Hand pump	16 min	28 min	40 min
12v Automotive and battery pump	11 min	18 min	25 min
220v Electric pump	5 min	9 min	13 min



## SAFETY FEATURES

Fire protection class	B1
Water resistant	2000 mm



## ROOF COLORS

Black	Light Grey 422 C	White	Blue 300 C	Red 200 C	Navy 2767 C



## SCOPE OF DELIVERY - STANDARD SET

1 x Roof
1 x Inflatable
1 x Removable Roof option
1 x One-Pump-System
1 x Sand bag set (4 pcs)
1 x Transport backpack
1 x Double Action Hand pump
1 x Repair set
1 x Guy ropes (4 pcs)



## ADDITIONAL ITEMS

Waterbags (in addition or instead of Sandbags)	
Watertubes (to pin down the side panels)	
Side panel 1 continuous	
Side panel 2 with PVC window / mesh window	
Side panel 3 with vertical zipper	
Side panel 4 with oval zipper	
Side panel 5 continuous PVC material	
Side panel 6 continuous mesh material	
Side panel dz with two zippers *	
Side panel rz for turning over the side panel *	
Fusion 4000 / 4050 / 5000 / 5060 / 6000	
Sunshade	
Shade Extender	
Double Action Hand pump / 12V Automotive and battery pump / 220V Electric pump	





Das Auto.



Das Auto.

Das Auto.

Das



Wir leben durch



GYBE

GYBE



 GYBE

**GYBE® PRODUCTS, AS INDIVIDUAL AS OUR CUSTOMERS.**



## THE GYBE® COUNTER

The GYBE® Counter is an inflatable mobile sales counter for exhibitions, events and promotion.

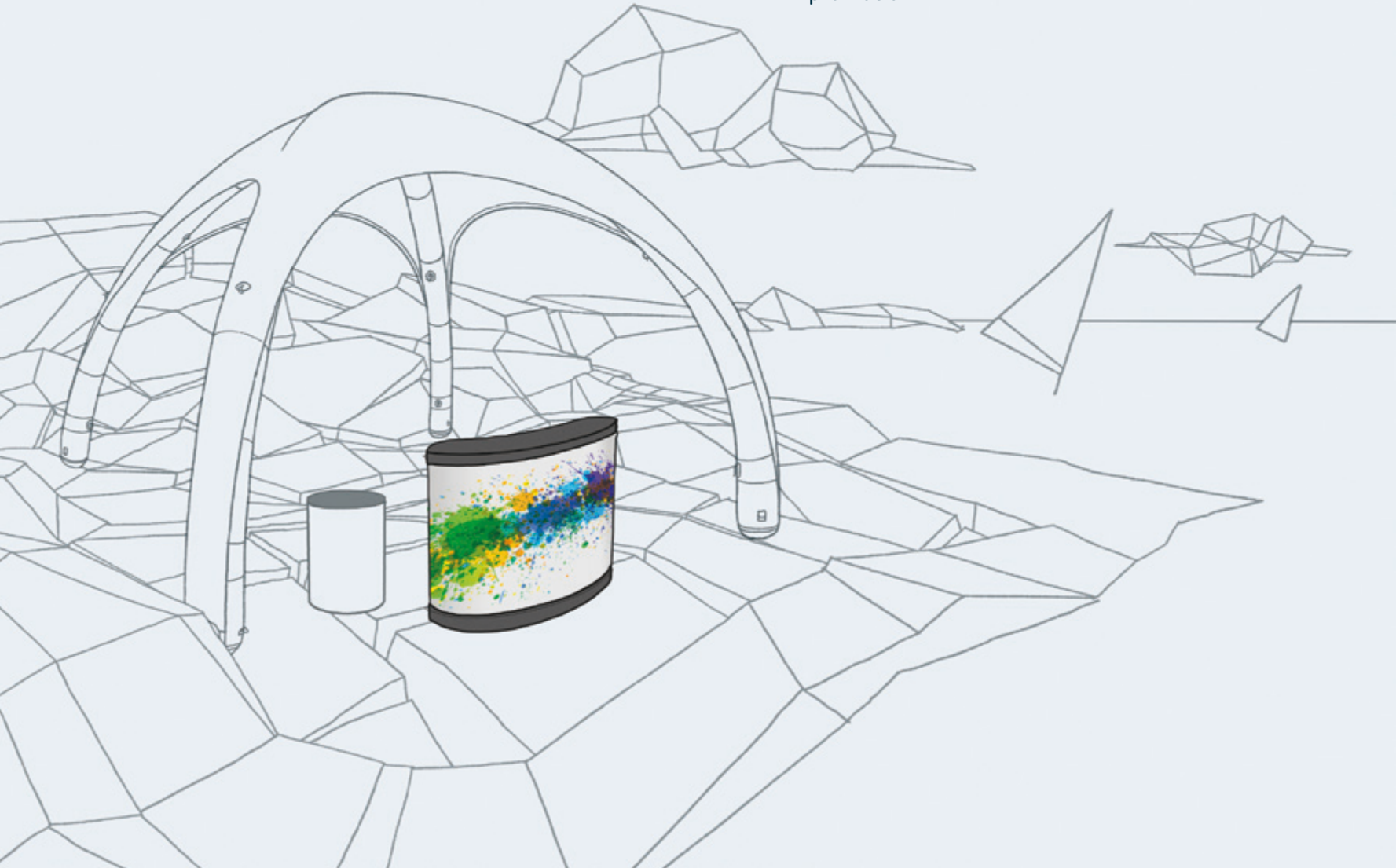

## UNPACK - INFLATE - READY!

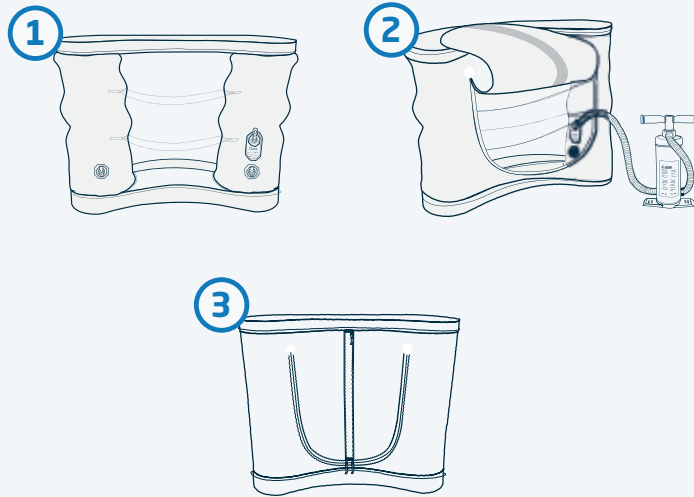

The GYBE® Counter is built up in just three steps: Attach the pump hose into the inflation valve, fill the struts and the counter will be ready.

Due to the small packing size, the transport is comfortable and flexible to use.

## CUSTOMIZABLE

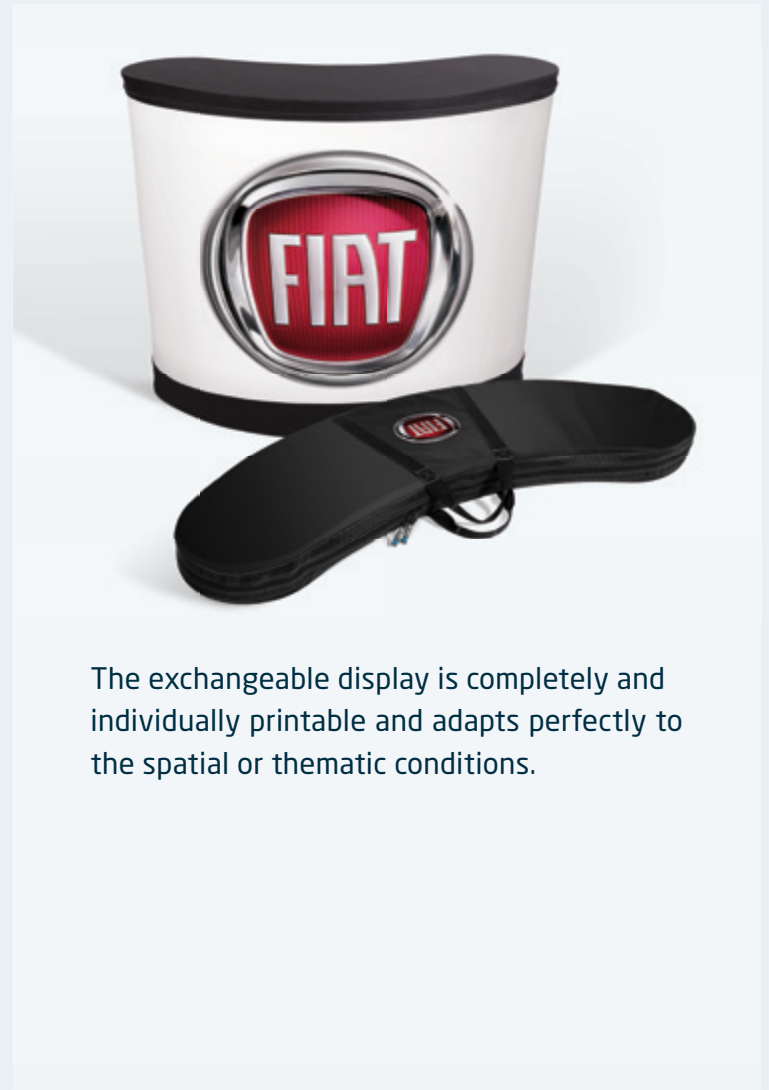

The exchangeable display is completely and individually printable and adapts perfectly to the spatial or thematic conditions.



  
CHEVROLET



CHEVROLET



CHEVROLET

FIRMENICH

FIRMENICH

adidas

adidas

! good  
! out  
! you!



## DIMENSIONS

Height	1.04 m
Width	1.22 m
Depth	0.36 m



Weight	14 KG
--------	-------



## SET UP TIME

Double Action Hand pump	5 min
12V Automotive and battery pump	1 min



## SCOPE OF DELIVERY

1 x Counter (Tabletop + lower part, inflatable)
1 x Removable Display (incl. Digital sublimation fullprint)
1 x Transport bag
1 x Double Action Hand pump
1 x Repair Set



## ADDITIONAL ITEMS

Removable Display
220V Electric pump

## THE GYBE® COUNTER - DISPLAY YOUR BEST SIDE





## THE GYBE® SITTING TUBE

The GYBE® Sitting Tube is an inflatable seating for fair und events.

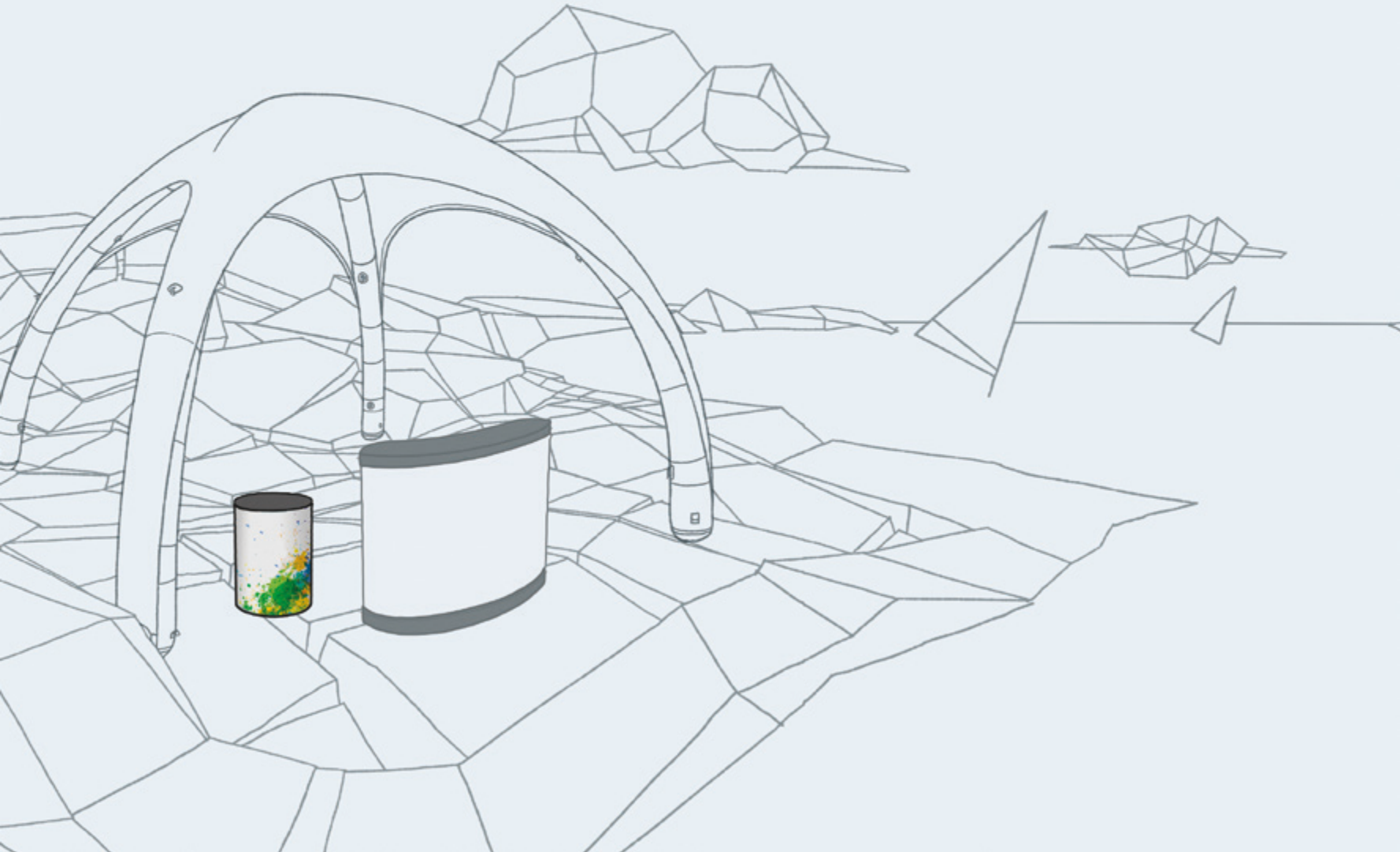

## SIMPLE AND COMFORTABLE



The GYBE® Sitting Tube is build-up quickly and easily.

Attach the pump hose into the inflation valve. fill the Sitting Tube - ready.

## TECHNICAL DETAILS

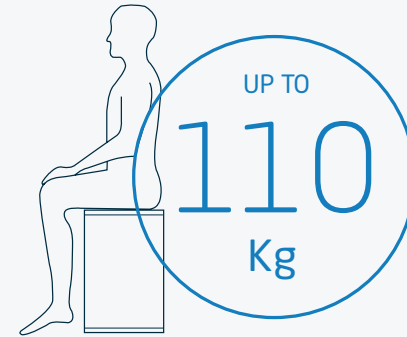

CERTIFIED ACC. TO:

DIN EN 581

The GYBE® Sitting Tube is DIN certified and can be used up to 110kg.

It is completely printable and customziable to your concept.



## DIMENSIONS

Height	51.0 cm
Diameter	39.0 cm
Circumference	122.5 cm



## SCOPE OF DELIVERY

- 1 x Inflatable stool (incl. Digital sublimation fullprint)
- 1 x Transport bag



Weight	1.6 KG
--------	--------



## SET UP TIME

- Double-stroke hand pump 1 min

## THE GYBE® SITTING TUBE - TAKE A SEAT!



## THE GYBE® STAR LOUNGE

GYBE® complemented the Star Tent with a unique luminous source that creates a lounge-atmosphere which can be used versatile for your promotion or festivals.

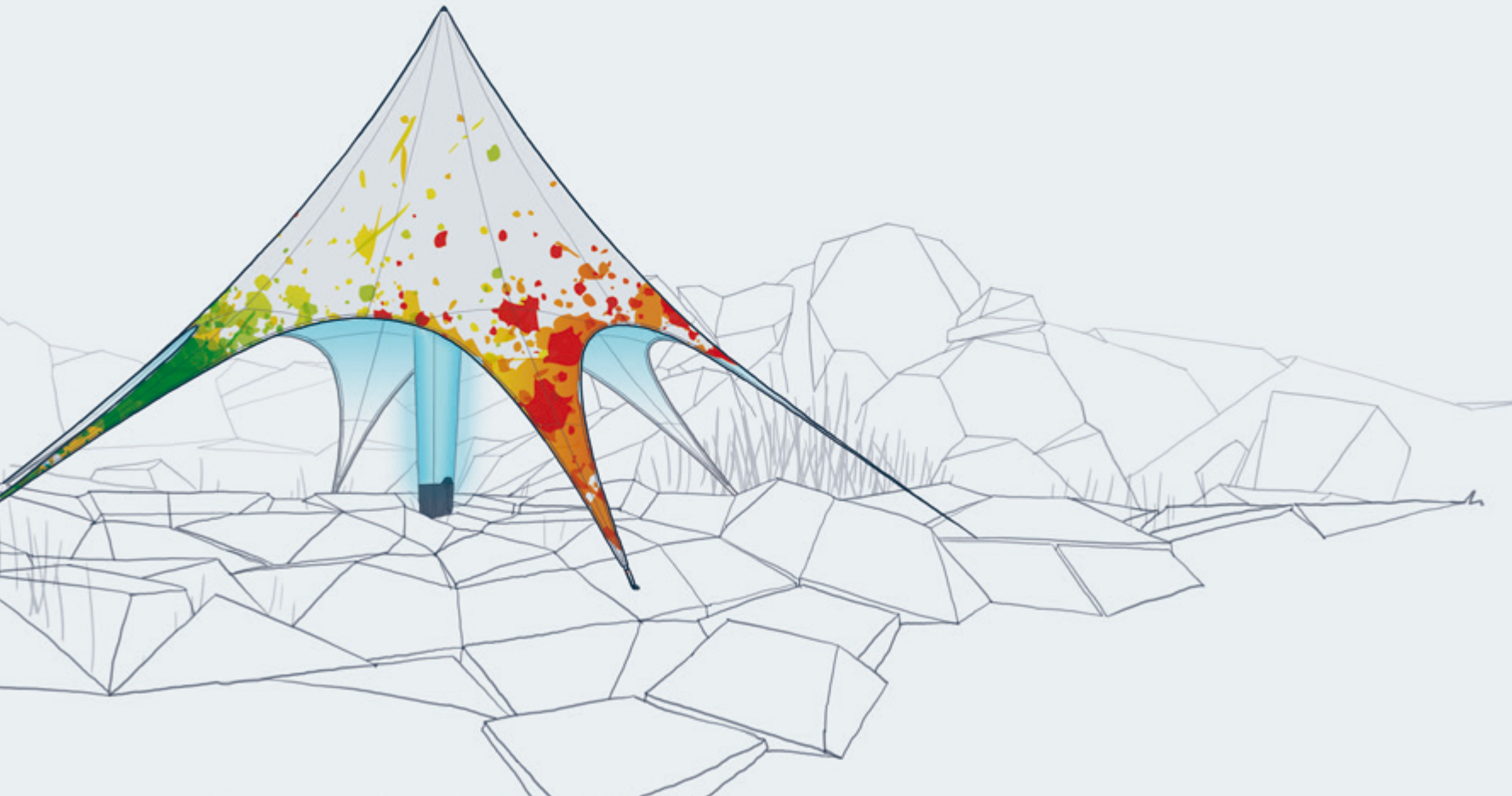

## UNPACKING - INFLATING - SPOT ON!

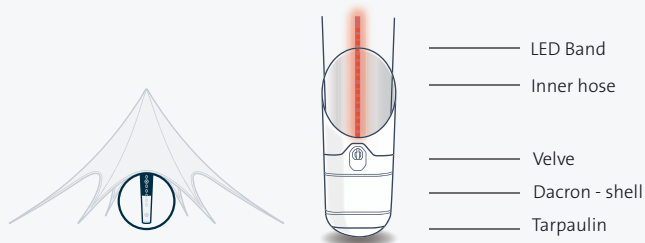

The inflatable supporting structure is built-up in just a few minutes.

The GYBE® STAR LOUNGE contraction allows an easy transport and it is lighter and smaller packed than conventional tents.

## ADVERTISEMENT AND ILLUMINATED STRUCTURE

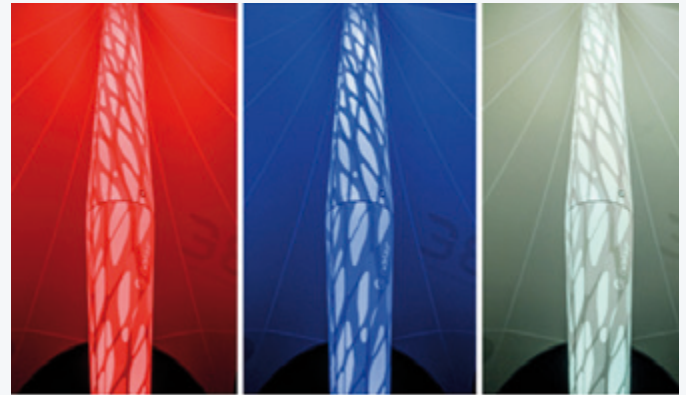

The central strut is replaced with an inflatable support structure which can be individual printed to your special needs. The inflatable can also be adapted in color upon request.

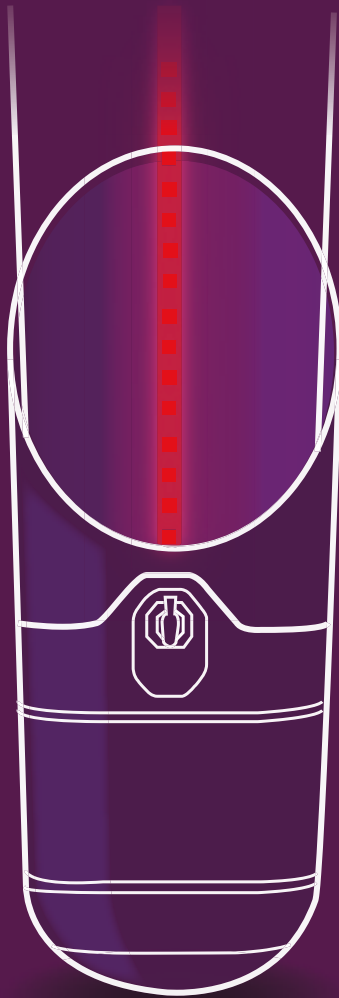

## THE LIGHT COLUMN

The integrated 12V light band with 120 RGB-diodes per meter spreads over the whole height of the support structure. Through the interaction of the red, blue and green LEDs in the column it is possible to reproduce every colour of the RGB-spectrum. The light band's intensity is very high due to the high number of diodes.

## FEATURES

All extensions can be customized by different printing processes and will perfectly match to the high demands.

## STRUT WITH RGB-LED BAND



By using the integrated LED-BAND, the inflatable support structure can be illuminated into 16.7 million different colour moods and light intensities (RGB-spectrum/range). You can control all the functions like colour shade, intensity and lighting effects easily by using the touch-remote-control.

## SIDE PANELS



For the STAR LOUNGE GYBE offers four different types of sidepanels, which can be exchanged to your desires.

## EXTENSION MODUL



In combination with the Sun-Shade, the extension panel allows to connect two similar sized tents. This creates an impressive lounge area for your event.

## SUN SHADE



The Sun Shade extends the shadow area of your STAR LOUNGE and allows to connect another tent.







## DIMENSIONS

	11 m	14 m
Height	5.4 m	6.2 m
Width	11.0 m	14.0 m
Length	11.0 m	14.0 m
Base area	78.0 m <sup>2</sup>	127.0 m <sup>2</sup>
Height of doorway	2.2 m	2.45 m



Weight	20 KG	28 KG
--------	-------	-------



## SET UP TIME

	11 m	14 m
Double action hand pump	20 min	25 min
12V Automotive and battery pump	15 min	18 min
220V Electric pump	10 min	12 min



## SAFETY FEATURES

Fire protection class	B1
Water resistant	2000 mm



## ROOF COLORS

Black	Light Grey 422 C	White	Blue 300 C	Red 200 C	Navy 2767 C



## SCOPE OF DELIVERY

1 x	Roof
1 x	Inflatable without RGB-LED light
2 x	Pegs 30 cm
6 x	Pegs 50 cm
1 x	Transport bag
1 x	Double action hand pump
1 x	Assembly aid



## ADDITIONAL ITEMS

Inflatable with RGB-LED light	
Inflatable without RGB-LED light	
Side panel 1 continuous	
Side panel 2 continuous PVC	
Side panel 3 with vertical zipper	
Side panel 4 continuous mesh material	
Roof	
Sunshade	
Fusion 11 > 11 m or Fusion 14 > 14 m	
Extension Module	
Double action hand pump / 220V Electric pump / 12V Automotive and battery pump	

**PRINTING OPTIONS**



## IF THE DESIGN IS REAL, THEN OUR REALITY IS BRILLIANT

The GYBE® products are not only impressive because of their remarkable design. Thanks to a modern printing process, the GYBE® Event Tent can be printed photorealistic. By means of a new refining method, your tent becomes a canvas of brilliant photos with impressive sharpness, high color intensity and captivating resolution.

The GYBE® products therefore attract everyone's attention and turn into a unique advertising space. Furthermore, the new printing process makes it possible to individually color the outer panels of the Roof and Sides.



**DURABILITY**



**4C-COLOR PRINT**



**BRILLIANCE**

## SUBLIMATION PRINTING

Sublimation printing is a process in which the color pigments are brought deeply into the printable material. A sublimation foil is digitally printed in photo quality and then with pressure and heat transferred to the material.

The printing result is extremely brilliant because the warmth gives the pigments a winning brightness and they durably adhere to the fabric. Sublimation printing is extremely suitable for large or fullprint designs. You can print over the complete length and breadth of the material which enables the coloring of the Roofs or Sides in your Corporate Identity colors.

①

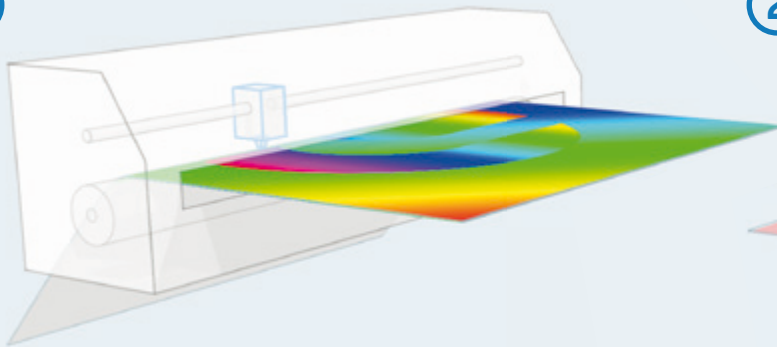

### STEP 1

First, the special foil is printed with the wished design on the reverse. The applied ink contains many chromophoric pigments and is highly concentrated.

②

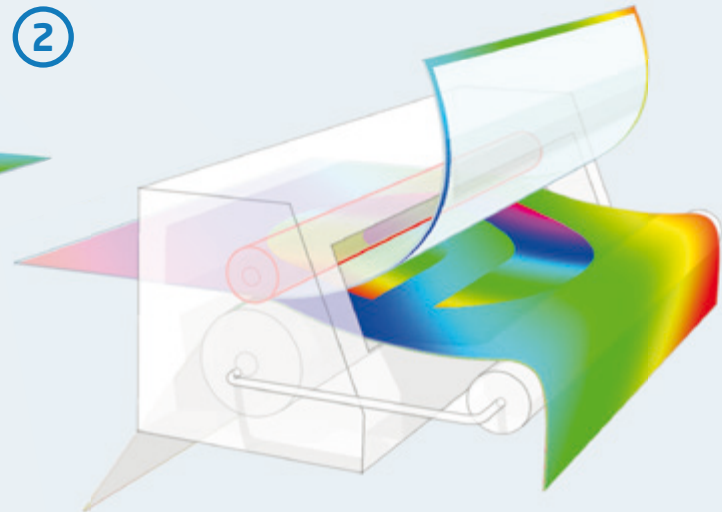

### STEP 2

Subsequently, the material to be printed and the special foil are pulled together through a heating press. Here the colorant from the carrier foil is transferred to the material under high pressure and temperature.

## TRANSFER PRINTING

As opposed to sublimation printing, transfer printing is especially suitable for small to medium-sized designs, which are to be shown advantageously on colored material.

Latex ink is digitally printed in photo-quality on the carrier foil. This foil is then cut to size according to the design and then transferred under pressure and heated on the surface of the material. Since the carrier foil is white, colored materials can also be printed. The printing result is absolutely brilliant, also on black materials.

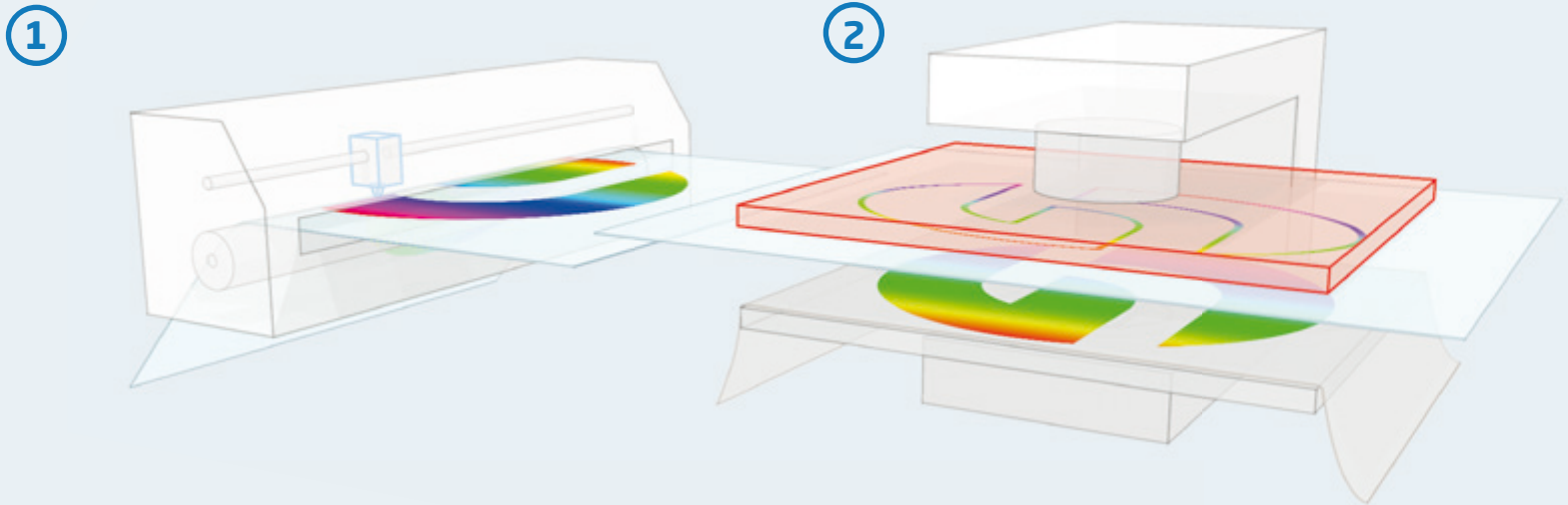

### STEP 1

First, the special foil (transfer) is printed with the required design.

### STEP 2

Subsequently, the transfer foil is cut to size with the help of the design. The cut-out material to be printed on is spread out crease-free on the transfer press and the transfer foil positioned on the material. Under heat and high pressure the transfer foil is transferred to the material.





## IMPRINT

### SALES GERMANY

CYBE® Design Team Germany GmbH  
Rheinstraße 39  
26382 Wilhelmshaven  
GERMANY

### MORE INFORMATIONEN

[www.gybe-design.com](http://www.gybe-design.com)  
[info@gybe-design.com](mailto:info@gybe-design.com)

### CONTACT

tel +49 (0) 4421 / 98 78 89 2  
fax +49 (0) 4421 / 98 78 89 7

CYBE® is a division of  
Adventure Design GmbH  
Selneckerstrasse 20  
04277 Leipzig, Germany

